

R/A COAX PLUG+HOUSING

R197.120.E00

CABLE 2.6/50

Series : CARLOCK

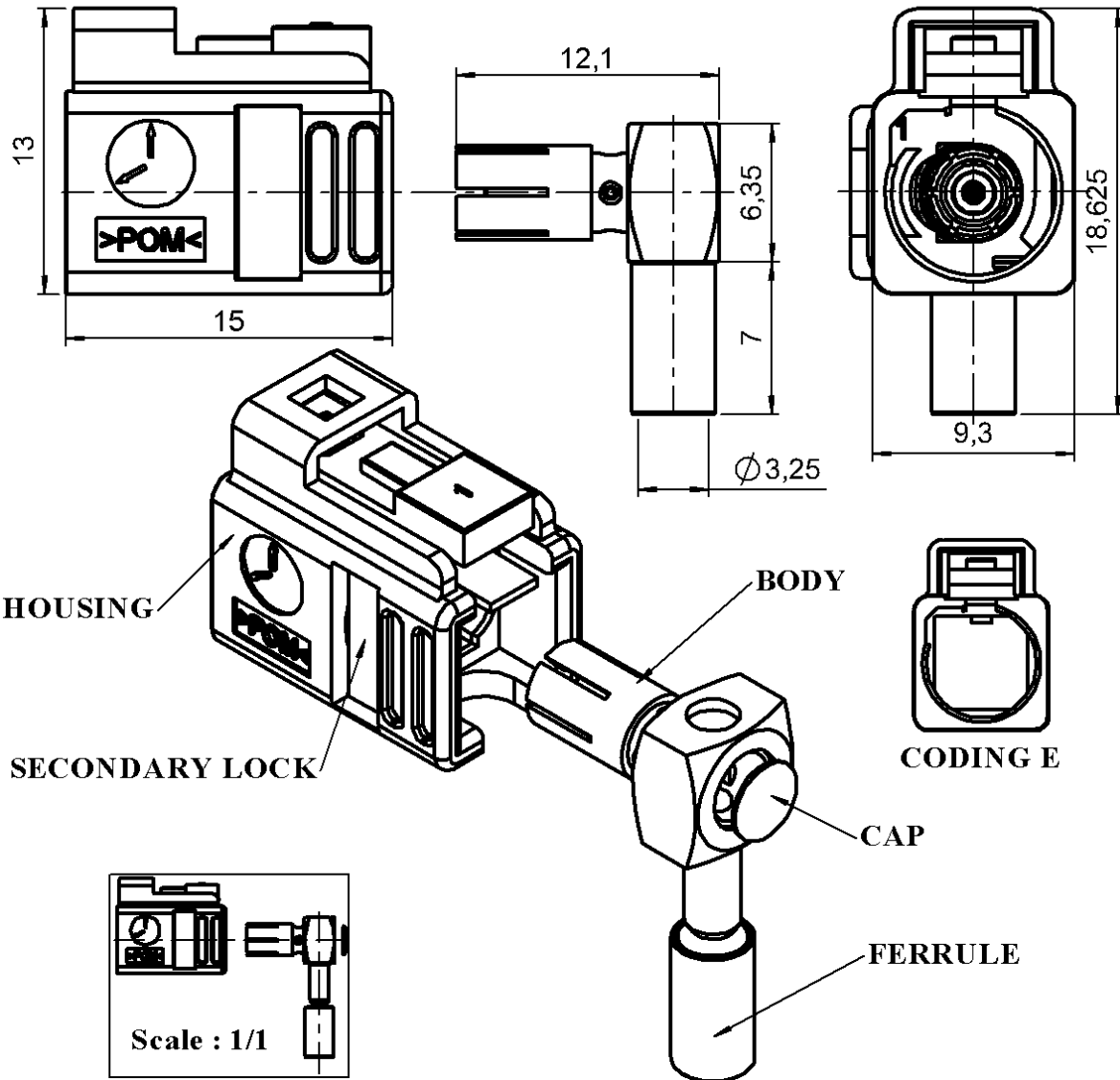

All dimensions are in mm.

COMPONENTS	MATERIALS	PLATINGS (µm)	
BODY	BRASS	NICKEL .	
CENTER CONTACT	BRONZE	GOLD OVER NICKEL	
OUTER CONTACT	BRONZE	NICKEL .	
INSULATOR	PTFE		
GASKET	-		
OTHERS PARTS	BRASS	NICKEL .	
HOUSING	Polyoxyméthylène (POM)	UL CLASSIFICATION	COLOR
Secondary Lock	Polyoxyméthylène (POM)	UL 94 V-2	GREEN RAL6002
		UL 94V-2	PURPLE RAL4006

*According to FAKRA specifications

Issue : 0035 A

In the effort to improve our products, we reserve the right to make changes judged to be necessary.



R/A COAX PLUG+HOUSING
CABLE 2.6/50

R197.120.E00

Series : CARLOCK

PACKAGING

Standard	Unit	Other
100	'W' option	Contact us

SPECIFICATION

ELECTRICAL CHARACTERISTICS

Impedance	50	Ω
Frequency range	0-2	GHz
	Frequency	1GHz 2GHz
	VSWR	1.1 1.040
Insertion loss	0.25	\sqrt{F} (GHz) dB Maxi
RF leakage	- (- F(GHz)) dB mini
Voltage rating	335	Veff Maxi
Dielectric withstanding voltage	1000	Veff mini
Insulation resistance	1000	M Ω mini

CABLE ASSEMBLY

Stripping	a	b	c	d	e	f
mm	2.00	5.00	9.00	7.00	0.00	0.00

Assembly instruction : **page 4**

Recommended cable(s)

- RG 174
- KX 3B
- RG 188
- KX 22A
- RG 316

Cable retention
- pull off **120** N mini
- torque N.cm

MECHANICAL CHARACTERISTICS

Center contact retention		
Axial force – Mating end	10	N mini
Axial force – Opposite end	10	N mini
Torque		N.cm mini

TOOLING

Part Number	Description	Hexagon
R282.211.000	CRIMPING TOOL	3.25
R282.235.003	CRIMPING DIES	M22520/5-03
R282.293.000	CRIMPING TOOL	M22520/5-01

Recommended torque		
Mating		N.cm
Panel nut		N.cm
Clamp nut		N.cm
A/F clamp nut	0.000	mm

Mating life	100	Cycles mini
Weight	2.608	g

OTHERS CHARACTERISTICS

Housing locking strength 80 N mini
Sealing protection NA

ENVIRONMENTAL

Operating temperature	-40/+110	$^{\circ}$ C
Hermetic seal		Atm.cm3/s
Panel leakage		

Issue : **0035 A**

In the effort to improve our products, we reserve the right to make changes judged to be necessary.



R/A COAX PLUG+HOUSING

R197.120.E00

CABLE 2.6/50

Series : CARLOCK

VSWR

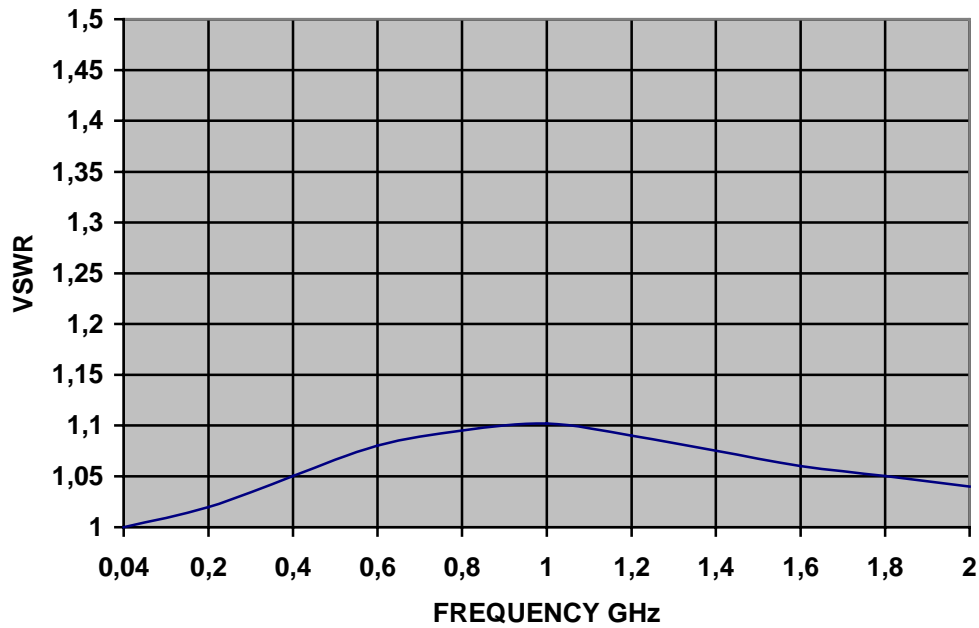

Issue : 0035 A

In the effort to improve our products, we reserve the right to make changes judged to be necessary.





R/A COAX PLUG+HOUSING

R197.120.E00

CABLE 2.6/50

Series : CARLOCK

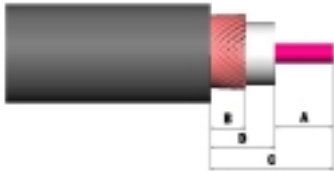
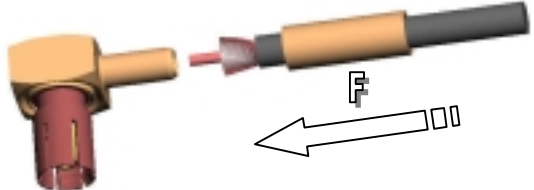
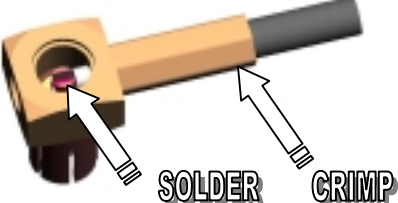
RECOMMENDED MOUNTING PROCEDURE

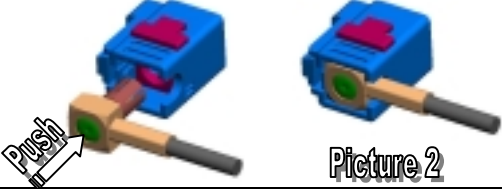
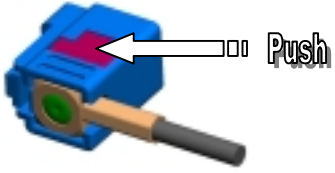
<p>1</p> <ul style="list-style-type: none"> • Slide onto the cable the ferrule • Strip the cable 	
<p>2</p> <ul style="list-style-type: none"> • Fan the braid • Push connector body under the braid • Slide the ferrule on the braid (in direction F) 	
<p>3</p> <ul style="list-style-type: none"> • Crimp the ferrule with crimping tool R282.211.000 (Hex:3.25) or crimping tool R282.293.000 (M22520/5-01) + dies R282.235.003 (M22520/5-03) • Solder inner conductor 	
<p>4</p> <ul style="list-style-type: none"> • Place the cap • Press cap flush or slightly below surface of body assembly 	
<p>5</p> <ul style="list-style-type: none"> • Push the coax in the housing till it snap on (according to picture 2) 	
<p>6</p> <ul style="list-style-type: none"> • To secure the coax inside the housing , push the secondary lock in final position (until it click on) 	

Issue : 0035 A

In the effort to improve our products, we reserve the right to make changes judged to be necessary.

